

ANALYSIS OF QUALITY CONTROL OF THE GRAPHITE PROCESS ON THE EXAMPLE OF A COMPANY FROM THE AUTOMOTIVE INDUSTRY

Andrzej PACANA^{1*}, Karolina CZERWIŃSKA²

¹ Rzeszow University of Technology, Faculty of Mechanical Engineering and Aeronautics, Rzeszow, Poland;
app@prz.edu.pl, ORCID: 0000-0003-1121-6352

² Rzeszow University of Technology, Faculty of Mechanical Engineering and Aeronautics, Rzeszow, Poland;
k.czerwinska@prz.edu.pl, ORCID: 0000-0003-2150-0963

* Correspondence author

Abstract: The visual method is one of the most important control methods in spite of the developing information technologies and very high automation of the production process. The aim of the article is to analyze the quality control of a selected part of the production process of pistons for passenger cars, for which the visual method is used, and to evaluate the application of this method as well as its influence on the improvement of the presented production process. The analysis made it possible to assess the impact of the type of non-compliance and location on the effectiveness of controls. Thanks to the analysis carried out, the dominant influence of factors, which depend on the person performing the control, on the effectiveness of the control was found.

Keywords: production process, quality control, visual quality control, PFMEA method.

1. Introduction

Both in production engineering and in any human decision-making activity, the ability to discover, understand and then solve problems is essential. In order to manage rationally, more and more attention needs to be paid to making rational decisions about the operational and strategic activities of the company. Successful actions resulting from these decisions are the result of the knowledge of mechanisms and rules governing manufacturing processes, as well as the ability to react quickly to a specific state of the process. Not without significance is the question of the available tools supporting the decision-making process, the data of which are the basis of the analyses conducted. The data used to evaluate manufacturing processes is provided by quality control (Hamrol, Kowalik, 2002; Vogt, Kujawińska, 2013).

The term quality control can be interpreted in many ways (Hamrol, 2008; Raz, Liittschwager, 1989; Kolman, 1998). The study assumes that it is a check of compliance of the product or process with internal or external requirements (Hamrol, 2008). Quality control is most often carried out by direct measurement or observation route, while its results constitute the obtained data enabling the analysis of the evaluated state of the process.

The primary objective of quality control is to monitor the process or product and eliminate the causes of unsatisfactory achievements in terms of the appropriate quality level, which in turn affects the economic efficiency of the company (Lisowski, 2004; Mitra, 1998).

At present, it is not easy to find a production sector which does not meet the demands resulting from quality control. It plays a key role in various branches of industry, especially where its results are of great importance to the customer. An example is the production of medicines, surgical instruments, airplanes or passenger cars, where there is a significant impact of product quality on human health and, in special situations, on the life of the recipient of the product.

Along with the technological development, more and more operations in the manufacturing process are performed by machines, human involvement seems to be marginal but still necessary. Despite the fact that most of the industries (e.g. pharmaceutical or automotive) are usually operated automatically, human presence is still necessary. A person with an advantage over the device is able to perform unique operations, requiring a flexible approach depending on the current situation. A particularly important role is assigned to man in quality control.

Among the most commonly used alternative control methods, the most common is still the visual one, which is man-made, machine or hybrid man-machine. In some situations, automatic optical systems cannot guarantee an adequate level of repeatability and reproducibility of the inspection, and human visual quality control is the only solution (Hamrol, 2005).

2. Visual quality control

The visual method is considered to be the basic diagnostic method. This method consists in checking with the naked eye or using an optical device whether any discrepancies are present on the surface of the tested product and then measuring their characteristic dimensions. Visual inspection often requires appropriate equipment, depending on the type of production, diagnosed products and industry. The main requirements for a properly conducted examination are: good eyesight of the examiner, appropriate qualifications, ability to distinguish and interpret non-conformities, as well as sufficient light intensity. As a rule, visual inspections should be performed as a priority in the tests carried out (Nęcki, 2015).

The lack of stability of the production process results in the fact that the visual method has been applied in a large number of stages of the production process. Despite its imperfections and the risk of not detecting incompatibilities, the dominant role in this method is played by man. Measurement, assessment of whether checking one or more properties of an object or process and subsequent comparison of the results with the requirements is aimed at assessing the conformity of the product (Hamrol, 2011). The most frequently specified activities relate to the indicated aspect of the quality of the part or process, obtained at the stage of creation or operation of the object. They are used to compare the quality of the product with the intended quality level. Such inspection activities are usually carried out by specialised personnel with experience in the manufacture of the product being inspected. These activities are usually not the responsibility of production workers, but there are production sectors in which visual inspection is performed by production operators operating the machines. Products not complying with the specification are rejected for disposal or sent for improvement (Hamrol, Mantura 2011). The main purpose of visual inspection is to separate non-conforming products with the naked eye of non-conformity. Quality control can be considered effective if all non-compliant products are eliminated from the sample without mistakenly rejecting a conforming product.

Visual inspection is considered to be an economically viable activity which does not require the involvement of expensive equipment. It is an additional non-destructive method, i. e. it does not lead to wear and tear of the assessed product. Using visual quality control, one cannot neglect its weaknesses – reliability; even a 100% verification does not guarantee the improvement of the assessment (Vogt, Kujawińska, 2013). Table 1 shows four possible decisions depending on the visual inspection assessment of the condition of the product.

Table 1.

Four possible decisions in the visual inspection of product quality

Decision	Actual condition of the product	
	Defective product (NOK)	Good product (OK)
Rejection	Right decision: rejection of the product	Wrong decision: rejection of the product
Acceptance	Wrong decision: Acceptance of the product	Right decision: Acceptance of the product

Source: Szafranski, 2006.

As shown in Table 1, two types of errors can be made in the visual evaluation process: a good product can be classified as non-compliant or a non-compliant product as good. The probability of these errors and the fraction of non-compliant parts after the control process are the key indicators for assessing the effectiveness of visual control (Flat, 2001). An exemplary measure of the visual effectiveness of quality control is the First Pass Yield (FPY) indicator (Szafranski, 2006).

$$FLY = \frac{\text{number of non – compliances detected the first time}}{\text{total number of non – compliances at a given stage of the process}} \cdot 100\% \quad (1)$$

The value of the FLY indicator is in the range of 0-100%. A low value of the indicator means that the control is ineffective. The maximum value of the FLY indicator implies that each non-conformity is detected in the control on the first try and thus that none of the non-conformities is passed through to the following stages of the process.

3. The FMEA method of the process

Process planning analysis is carried out during the design work on a new process or during the improvement of an existing process. This analysis is used to eliminate process defects as well as non-conformities of the product resulting from the process. The PFEA is also intended to reduce the level of unavoidable costs caused by non-compliance as well as corrective and preventive action. The FMEA of the process refers to the method of action and appropriate supervision to ensure compliance with the requirements for the operation of tools, equipment and machines as well as the relevant behaviour of employees involved in the process analysis (Pacana, Zieliński, Bartkiewicz, 2015; Pacana, Czerwińska, Siwiec, 2018). PFMEA is recommended to be carried out, among others: before the start of serial production, during the design of a new process and improvement of an existing process, or if the process does not produce the expected results or is unstable (Sęp, Perłowski, Pacana, 2010). Improvement of work safety and ergonomics is also a positive aspect of this analysis, and therefore the problem should be properly formulated in the process analysis, taking into account its consequences for employees (McDeermont, 2009).

4. Process – piston graphite

The graphite process is applied to the piston casing designed for a diesel engine used in passenger cars. The model of piston together with the description of its construction is shown in Figure 1. The pistons are produced in one of the plants in the south of Poland.

The graphite-riding process is designed to coat the metal surfaces (jacket) of the piston with a graphite coating to reduce friction. Graphite-riding is carried out by means of the ATMA device. Graphite paste is used for graphite, which is supplied in a ready-to-use form as a mixture of graphite, resins and solvents.

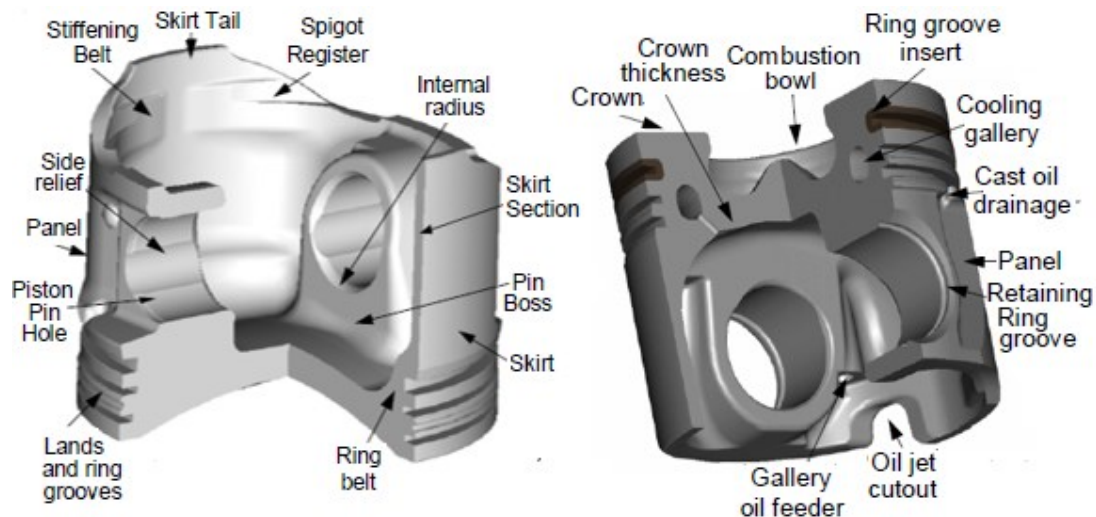

Figure 1. Piston model with description of its construction. Adapted from: Dokumenty udostępnione przez Federal Mogul Gorzyce. Materiały niepublikowane, Gorzyce, 2014.

Graphite paste is applied to the surface of the piston shell by silkscreen printing. At the beginning, the appropriate thread is poured onto the screen of the graphite machine, then the screen, the appropriate pressure and the angle of inclination of the pressure rubber are set in such a way as to obtain the appropriate distribution of graphite and the correct thickness, according to the process. After performing tests and obtaining appropriate parameters, the products are graphitised. Then the batch of pistons is placed on transport trolleys and subjected to the process of heating in electric furnaces at a suitable temperature.

5. PFMA analysis of the piston graphite process

The PFMEA analysis was prepared on the basis of documentation of the technological process of graphitization of the piston shell. This analysis is presented in Table 2. In each technological process operation, the following is defined:

- the emergence of potential defects that may occur during the implementation of the process,
- the existence of potential effects of the defect which may contribute to the production of the piston casing,
- the existence of potential causes in the occurrence of individual defects in each operation.

For defects, effects and causes of defects, numerical values have been assigned to indicators:

- LPW – the risk of frequent occurrence of defects on a scale of 1-10 (1 – very low; 10 – very high),
- Z – significance of the defect on a scale of 1-10, (1 – very low; 10 – very high),
- W – detection of defects on a scale of 1-10, (1 – very low; 10 – very high).

Table 2.
PFMEA analysis of piston shell graphitization process

Proces	Type of potential defect	Potential effects of the defect	Rele	Potential cause / defect mechanism	Occurrence	Ongoing process controls Prevention	Ongoing process controls Detection	Dete	LPR
Piston graphiting (ATMA device) and baking (LAC furnace)	Graphite layer too thick	The piston cannot be mounted in the cylinder	8	Incompatible distance between the rubber and sieve	2	Employee training Graphite layer thickness measurement First piston when setting up the machine	Graphite layer thickness measurement every 2 hours. 100% visual inspection of the graphite layer before loading into the furnace 100% dimensional inspection in op 300	5	84
	Thickness of graphite layer too low	Piston seizure	8	Incompatible distance between the rubber and sieve	2	Employee training Graphite layer thickness measurement First piston when setting up the machine	Graphite layer thickness measurement every 2 hours. 100% visual inspection of the graphite layer before loading into the furnace 100% dimensional inspection in op 300	5	80
			8	Improper rubber angle	2	Employee training Graphite layer thickness measurement First piston when setting up the machine	Graphite layer thickness measurement every 2 hours. 100% visual inspection of the graphite layer before loading into the furnace 100% dimensional inspection in op 300	5	80
	Uneven graphite thickness	Piston seizure	8	Worn out / damaged pressure rubber	2	Employee training Graphite layer thickness measurement First piston when setting up the machine	Graphite layer thickness measurement every 2 hours. 100% visual inspection of the graphite layer before loading into the furnace 100% dimensional inspection in op 300	5	80
	Dirt on the graphite surface - from paste	Improper piston running-in	6	Inadequate washing of the sieve	2	Operator training, Collection of graphite on the sieve, sieve washing 1x/300 pieces	Graphite layer thickness measurement every 2 hours. 100% visual inspection of the graphite layer before loading into the furnace 100% dimensional inspection in op 300	6	72
	Bubbles in the graphite	Reduced piston life	6	Air humidity too high	2	Operatortraining,	Air humidity control 1x/change. 100% visual inspection of the graphite layer before loading into the furnace Visual inspection 100% op. 280	6	72
	Graphite stains	Piston cannot be mounted in the cylinder	7	Incompatible setting of the graphite machine	2	Employee training, graphite layer thickness control 1st piston	Check the thickness of the graphite layer every 2 hours during operation. 100% visual inspection of the graphite layer before loading into the furnace Visual inspection 100% op. 280	6	84

Table 2.
PFMEA analysis of piston shell graphitization process continued

Proces	Type of potential defect	Potential effects of the defect	Rele	Potential cause / defect mechanism	Ocu rrenc	Ongoing process controls Prevention	Ongoing process controls Detection	Defe ction	LPR	
Piston graphiting (ATMA device) and baking (LAC furnace)	Incorrect reflection shape of the graphite surface	Improper piston running-in	6	Inappropriate cogwheel	2	Employee training, graphite position measurement 1st piston after setting up the machine	100% visual inspection of the graphite layer before loading into the furnace Visual inspection 100% op. 280	6	72	
	Incorrect position of the graphite layer	Reduced piston life	6	Inappropriate sieve	2	Employee training, graphite position measurement 1st piston after setting up the machine	100% visual inspection of the graphite layer before loading into the furnace Visual inspection 100% op. 280	6	72	
	Graphite infiltration	Too thick layer of graphite		7	Incorrect setting of the graphite machine	2	Employee training, graphite position measurement 1st piston after setting up the machine	Graphite thickness measurement every 2 hours. Visual inspection 100% op. 280 100% dimensional inspection in op 300	5	70
				7	Defective graphite sieve	2	Employee training, graphite position measurement 1st piston after setting up the machine	Graphite thickness measurement every 2 hours. Visual inspection 100% op. 280 100% dimensional inspection in op 300	5	70
	Inappropriate adhesion of the graphite surface to the piston material	Improper piston running-in, clogging of the piston		7	Incorrect temperature distribution in the furnace	2	Checking the furnace temperature 1x/change Continuous temperature measurement - sound signalling Checking the temperature distribution in the furnace 1x/3 month	Monitoring of adhesion of the graphite layer by thermal shock 1x/change Checking the adhesion of the graphite layer using the oil method is 1x/modification	5	70
				7	For a short warm-up time (belt speed not set correctly)	2	Automatic tact control of pallets in the furnace. Stopping the process in the event of a malfunction Checking the temperature distribution in the furnace 1x/3 months	Monitoring of adhesion of the graphite layer by thermal shock 1x/change Checking the adhesion of the graphite layer using the oil method is 1x/modification	5	70

Source: Own elaboration

FMEA analysis of the piston graphitization process enabled the detection of defects and their causes. The greatest risk of non-conformity in the production process results from the problem which most often lies in the system and method of production. The technical condition of machines and equipment is also important for the quality of the product. Observance of the specified prevention and detection actions of the production process may significantly reduce the occurrence of defects in the manufacturing process, which reduces the production costs and at the same time increases customer satisfaction and contentment.

6. Visual inspection of non-compliance with the highest risk of occurrence

Visual quality control is carried out in the company after the graphitization process. This control is carried out in accordance with the company's internal procedure according to each production order. Example results of discrepancies, which obtained the highest score in the FMEA analysis of the graphite process, are presented in Figures 2 and 3.



Figure 2. Graphite layer thickness too high.

The visual inspection results shown in Figure 2 illustrate the result of a very thick coating (> 20), which may cause the so-called orange peel effect and the surface covered with craters.



Figure 3. Graphite stains on the piston surface.

Graphite stains are unacceptable product incompatibilities caused by incorrect positioning of the machine.

7. Analysis of the effectiveness of qualitative visual inspection

Two types with different degrees of detection of incompatibility occurring on the piston shells were specified. Depending on the location of non-compliance, defects of known and repeatable location and accidental location occur on the surface of the product. In the first group there is a mismatch defined as too thick a layer of graphite, while in the second group there is a graphite spot on the surface of the piston (Figure 4).

The test was carried out in specific batches of products and at an appropriate time interval.

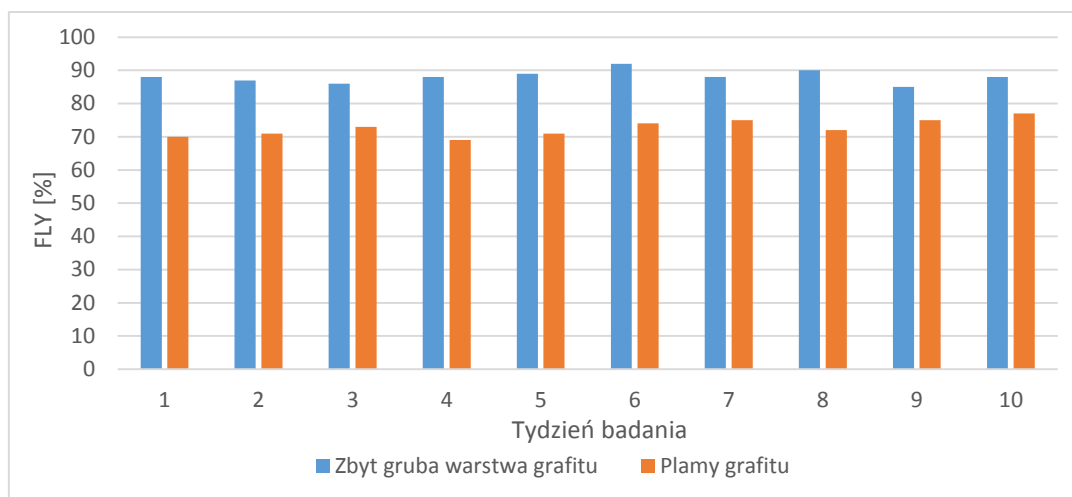

Figure 4. Value of the FLY indicator for the non-compliances identified.

Comparing the effectiveness of visual inspection for the listed non-conformities, based on the values of the FLY indicators (Figure 4), it can be seen that better detection is can be found in non-conformities whose location is determined and known to the operators. Incompatibilities the location of which is accidental turn out to be difficult for operators to detect in the piston evaluation process.

8. Summary

Despite its many obvious inaccuracies, such as the subjectivity of the assessment of the employee performing the inspection or ordinary human disabilities such as visual impairment, visual inspection remains one of the fundamental controls of the product and production process, especially in those branches of industry where the quality of the finished product depends on the conditions in the production hall, i. e. changing with the season, temperature or humidity. All these factors contribute to the fact that the production process has to be continuously regulated and the product has to be constantly controlled. If all this is translated into mass production, the visual inspection method remains a sensible and economically advantageous solution.

References

1. Dokumenty udostępnione przez Federal Mogul Gorzyce (2014). Materiały niepublikowane. Gorzyce.
2. Hamrol, A. (2005). *Quality Management with examples*. Warsaw: PWN.
3. Hamrol, A. (2008). *Zarządzanie jakością z przykładami*. Warszawa: PWN.
4. Hamrol, A. (2011). *Zarządzanie jakością z przykładami*. Warszawa: PWN.
5. Hamrol, A., Kowalik, D. (2002). FMEA w doskonaleniu procesów z dominującym udziałem człowieka. *Zeszyty Naukowe Politechnik Śląskiej*, 12.
6. Hamrol, A., Mantura, W. (2011). *Zarządzanie jakością. Teoria i praktyka*. Warszawa: PWN.
7. Kolman, R. (1998). *Poradnik kontrolera jakości*. Bydgoszcz: Ośrodek Postępu Organizacyjnego.
8. Lisowski, J. (2004). *Zarządzanie jakością w przedsiębiorstwie*. Białystok: Wydawnictwo Wyższej Szkoły Finansów i Zarządzania.
9. McDeermott, R.E. (2009). *Basics of FMEA*. New York: Productivity Press.
10. Mitra, A. (1998). *Fundamentals of quality control and improvement*. New Jersey: Upper Saddle River, Prentice Hall.
11. Nęcki, Ł. (2015). *Kontrola jakości procesu produkcji z wykorzystaniem metody wizualnej. Studium przypadku. Quality. Production. Improvement*. Częstochowa: Oficyna Wydawnicza Stowarzyszenia Menedżerów Jakości i Produkcji.
12. Pacana, A., Czerwińska, K., Siwiec, D. (2018). *Narzędzia i wybrane metody zarządzania jakością. Teoria i praktyka*. Częstochowa: Oficyna Wydawnicza Stowarzyszenia Menadżerów Jakości i Produkcji.
13. Pacana, A., Zieliński, K., Bartkiewicz, G. (2015). Analiza FMEA procesu przetwarzania płyt meblowych w firmie Batrix. *Logistyka*, 6.
14. Płaska, S. (2001). *Wprowadzenie do statystycznego sterowania procesami technologicznymi*. Lublin.
15. Raz, T., Liittschwager, J.M. (1989). Ten measures of inspection performance. *Journal of Quality Technology*, 21/2.
16. Sęp, J., Perłowski, R., Pacana, A. (2010). *Techniki wspomaganie zarządzania jakością*. Rzeszów: Oficyna Wydawnicza Politechniki Rzeszowskiej.
17. Szafranski, M. (2006). *Skuteczność działań w systemach zarządzania jakością przedsiębiorstw*. Poznań: Wydawnictwo Politechniki Poznańskiej.
18. Vogt, K., Kujawińska, A. (2013). Analiza wpływu wybranych czynników pracy na skuteczność kontroli wzrokowej. *Inżynieria Maszyn*, 18, 1.